



Secure Seal Tester for Glass Bottles



Model No. PSST-0115 NXG

Secure Seal Tester – Next Generation Model is a consistent tool useful to measure the thread and seal integrity on your glass beverage containers. The glass bottle seal tester has been designed to address the special needs of sealing beverage containers that use various seals, such as aluminum roll-on, twist crowns. By detecting gas leakage rather than liquid, the Secure Seal Tester gives more sensitive, accurate readings.

- HMI based Touchscreen Model
- Microprocessor based controls
- Automatic sample testing through easy pressure release mechanism
- Pressure, Inlet Pressure setting and Preset Timer functions incorporated in HMI for accuracy and repeatability
- Pressure Vs Time live graph
- Program profile for selecting test parameters and performing the test.
- Easy Data Management. User can create product identification, test pressure, time etc.
- USB option available for storing test data
- Data output in excel format.
- Current test running status display
- Changeable Pressure Units
- Inbuilt Calibration facility
- 2 layer safety container

Software Feature :

- Touch screens comply with IP65 / NEMA4 standards CE & UL approved
- 7" TFT LCD 65536 colours
- ARM9 32-bit CPU; Function keys
- 640 x 480pixels
- 8M Flash Memory
- 512K bytes
- SRAM Supports SM card

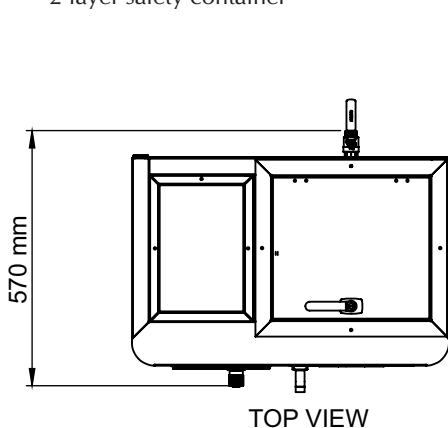

TOP VIEW

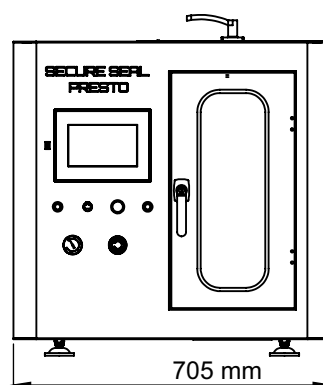

FRONT VIEW

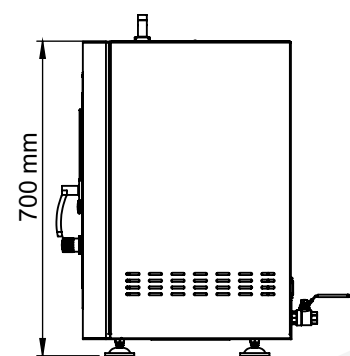

SIDE VIEW

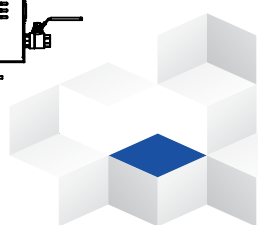



Presto Stantest Pvt. Ltd.

I-42, DLF Industrial Area Phase-1, Delhi Mathura Road, Faridabad 121003, Haryana, India
P : 9210 903 903, +91 129 4272727, 93111 24302 E : info@prestogroup.com

• Faridabad • Sonipat • Kolkata • Mumbai • Pune • Ahmedabad
• Chennai • Bangalore • Hyderabad

www.prestogroup.com



Key Specifications:

Display	HMI Based touchscreen
Equipment Range	220 psi
Test Range	175 psi
Accuracy	± 2% at full range
Least Count/Resolution	0.1 psi
Power	220V , Single phase, 50 Hz
Pressure Unit	Inbuilt in HMI (changeable in Kg/cm ² psi & bar
Inner Size of testing container	L 250 x W 225 X H 450 mm
Timer	Inbuilt in HMI Preset upto 999 seconds
Pressure Release	Auto pressure release system
Sample Holder	Piercing fixture for crown cap

Highlights:

Material	Test container poly carbonated sheet
Finish	Powder coated Havel Gray & Blue combination finish and bright chrome / zinc plating for corrosion resistant finish
Dimensions	705x570x700mm

- High pressure regulated air line not in our scope of supply

Optional Features :

- Piercing tool extra on chargeable

Thank you customers for choosing us as your partners in growth !



*All the above logos are the sole property of their respective owners and are used purely for depiction purposes only.

OUR OTHER PRODUCTS :-

					
Secure Seal Tester NXG	Secure Seal Tester	Wall Thickness Gauge	Gloss Meter Triangle	Moisture Analyzer MB 45	Preform Neck Cutter

